

Cisco 7600 Series 12-Port Channelized T3 to DS0 Optical Services Module

Cisco 7600 Series 12-Port Channelized T3 (CT3) to DS0 Optical Services Modules (OSMs) for channelized services enable the rapid, efficient addition of circuits within existing electrical connections. When a channelized circuit is established, all channels from DS3 to DS0 can be remotely provisioned, eliminating the need for the multiplexer line-card installations that are normally required to increase the available number of electrical circuits.

Coupled with numerous interfaces and native edge-aggregation services such as Multiprotocol Label Switching (MPLS) and Quality-of-Service (QoS), the Cisco 7600 Series 12-Port CT3 to DS0 OSM meets aggregation site connectivity requirements. Using channelized interfaces to receive multiplexed T1/E1 circuits on a single pair of optical fibers, service providers and large enterprises can save dramatically on power, floor space, local-loop charges, and equipment costs.

The Cisco 7600 Series 12-Port CT3 to DS0 OSM can accept both clear-channel T3 traffic and multiplexed circuits from T1/E1 and DS0. Service features include support for IP and MPLS traffic, Class-Based Weighted Fair Queuing (CBWFQ), Low-Latency Queuing (LLQ), and

Weighted Random Early Detection (WRED). Also included is support for hardware-enabled Multilink Point-to-Point Protocol (MLPPP), capable of up to 168 T1/E1 bundles supporting up to 12 T1/E1 links per bundle. With this combination of features and performance, Cisco provides a versatile electrical interface for the easy upgrade to the advanced network architectures provided by Cisco 7600 Series routers.

Service provider points of presence (POPs) and enterprise headend locations can use the Cisco 7600 Series 12-Port CT3 to DS0 OSM to enable rapid, efficient addition of circuits where density and performance are required. In topologies where wideband optical tributaries are not an option, the Cisco 7600 Series 12-Port CT3 to DS0 OSM is ideal for consolidation of circuits from multiple transport systems and facilitates rapid circuit cutover without having to rearrange tributaries within existing multiplexers.

Figure 1
Cisco 7600 Series
12-Port Channelized T3
to DS0 OSM

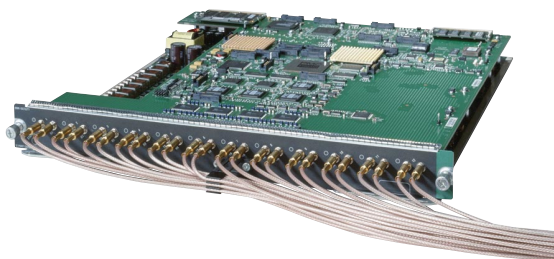



The Cisco 7600 Series 12-Port CT3 to DS0 OSM is ideal for several applications, including:

- Service provider edge offices or data centers aggregating circuits from multiple customer sites and locations
- Enterprises requiring bandwidth expansions (onsite multiplexers can be eliminated by directly receiving delivery of the “optical pipe”)

The Cisco 7600 Series 12-Port CT3 to DS0 OSM can efficiently aggregate several DS0, T1/E1, and DS3 circuits into a service provider POP or enterprise headend (Figure 2).

Figure 2

Aggregation Scenario Using the Cisco 7600 Series 12-Port CT3 to DS0 OSM

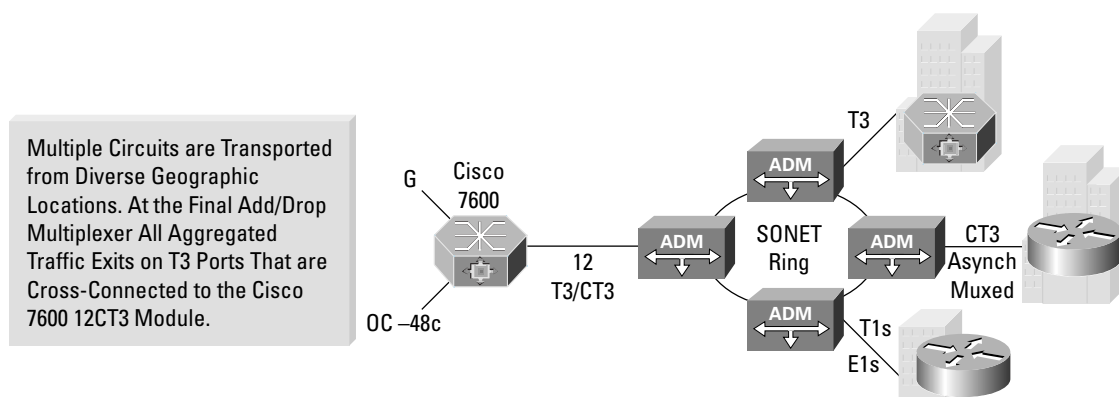

Table 1 describes the features provided in the Cisco 7600 Series 12-Port T3 to DS0 OSM.

Table 1 Cisco 7600 Series 12-Port T3 to DS0 OSM Features

Feature	Benefit
Encapsulations	Offers PPP, Frame Relay, and Cisco High-Level Data Link Control (HDLC).
MLPPP	Provides hardware-enabled MLPPP with up to 168 bundles and 12 T1/E1 links per bundle. QoS features such as CBWFQ and LLQ can also be applied over an MLPPP bundle.
Channel support	Supports up to 1023 channels per OSM with per-port selection of T3, nxT1, E1, or nxDS0 (see mapping section for more details).
CBWFQ	Implements CBWFQ using the Cisco Modular QoS command-line interface (CLI) (Cisco MQC) framework. CBWFQ manages link congestion by guaranteeing minimum bandwidth to predetermined traffic classes while fairly serving other classes of traffic in the network. CBWFQ on the CT3 can be implemented on logical interfaces, including nxDS0, nxT1/E1, and T3/E3.
LLQ	Implements LLQ using the Cisco MQC framework. LLQ manages link congestion by guaranteeing minimum bandwidth, giving highest priority to predetermined traffic classes while fairly serving other classes of traffic in the network. LLQ on the CT3 can be implemented on logical interfaces, including nxDS0, nxT1/E1, and T3/E3.



Table 1 Cisco 7600 Series 12-Port T3 to DS0 OSM Features

Feature	Benefit
WRED	Implements WRED using the Cisco MQC framework. The WRED algorithm provides congestion avoidance on network interfaces by providing buffer management, and by allowing Transmission Control Protocol (TCP) traffic to throttle back before buffers are exhausted. This helps avoid tail drops and global synchronization issues, maximizing network usage and TCP-based application performance. WRED can be implemented on logical interfaces, including nxDS0, T1/E1, T3/E3, and OC-3/STM-1.
MPLS	Plays several critical roles as an edge device, as a label-edge router for pure MPLS-based networks, and as a provider-edge device for MPLS virtual private networks (MPLS VPNs). The Cisco 7600 Series supports RFC-2547 and RFC-254-bis-based MPLS VPNs.
1023 virtual routing and forwarding (VRF) instances per chassis for MPLS VPN Layer 3 applications	Provides increased service density for MPLS/VPN services.
Upgradable programmed feature sets using the Cisco Parallel Express Forwarding (PXF) network processor	Offers greater flexibility to support new features through software upgrades, while delivering performance similar to application-specific integrated circuit (ASIC)-based designs.
Future support for Layer 2 network services	Provides network architectures based on Frame Relay and ATM over MPLS (Internet access and RFC 2547 VPNs).
256 MB direct memory access (DMA)	Supports larger traffic shaping queues. Enhanced OSMs support a minimum of 8000 QoS queues per Cisco PXF network processor.
Rapid provisioning and cutover of T3 circuits	Provides a dense, high-performance solution for T3 connectivity.
Reduced power consumption	Aggregates circuit terminations onto a single line card.
Compatible with Cisco 7600 Series and Cisco Catalyst® 6500 Series chassis	Offers flexibility and investment protection for customers with an installed base of either chassis.

Table 2 lists mapping information for the Cisco 7600 Series 12-Port CT3 to DS0 OSM.

Table 2 Supported Mapping of the Cisco 7600 Series 12-Port CT3 to DS0 OSM

T-carrier hierarchy	Clear channel or subrate T3; CT3 (28 x T1s); nxDS0 within T1 up to a total of 1023 channels per line card; and E1 to T3
----------------------------	---



Table 3 Ordering Information for the Cisco 7600 Series 12-Port T3 to DS0 OSM

Product Number	Description
OSM-12CT3/T1	12-port CT3 OSM with mini-SMB connectors (128-MB DRAM default)
OSM-12CT3/T1=	Cisco 7600 Series 12-Port CT3 to DS0 OSM with mini-SMB connectors (128-MB DRAM default), spare
MEM-OSM-256MB	256-MB error-correcting code (ECC) memory for Cisco 7600 Series 12-Port CT3 to DS0 OSMs (optional)
MEM-OSM-512MB	512-MB ECC memory for Cisco 7600 Series Optical Services Modules (optional)
CG-CT3=	Spare cable guide for Cisco 7600 Series 12-Port CT3 to DS0 OSM (reversible for horizontal or vertical installations)
Cable Options	
12-MINISMB/BNC-M	Set of 24 mini-SMB-to-male-BNC 10-ft coaxial cables (12 TX and 12 RX)
12MINISMB/BNC-F	Set of 24 mini-SMB-to-female-BNC 10-ft coaxial cables (12 TX and 12 RX)
12-MINISMB/OPEN	Kit of 24 mini-SMB-to-open-end 25-m coaxial cables for cut-to-length installations (no connector on one end)
MINISMB/BNC-M=	Two mini-SMB-to-male-BNC 10-ft coaxial cables (1 TX and 1 RX); spares (sold in pairs)*
MINISMB/BNC-F=	Two mini-SMB-to-female-BNC 10-ft coaxial cables (1 TX and 1 RX); spares (sold in pairs)*
MINISMB/OPEN=	Two mini-SMB-to-open-end 25-m coaxial cables for cut-to-length installations (no connector on one end); spares (sold in pairs)*

Note: The "=" at the end of the part number denotes a spare order (for example, an OSM-12CT3/T1= is a spare module, when not ordered in a system). Please note that spare cables are sold in sets of two cables (12 spare units are required to cable 12 ports).

Minimum Software Release

Cisco IOS® Software Release 12.1(13)E3

Technical Specifications

T3 Features

- CT3 with 28 T1s or 21 E1s
- Clear-channel DS3 supporting sub-rate and scrambling formats for Digital Link, ADC/Kentrox, Lar-scom, Adtran, and Verilink digital service units (DSUs)
- C-bit parity and M23 framing
- Bit error rate testing (BERT)
- Local and line loopback
- T3 facility data link (FDL)
- RFC 1407 Management Information Base (MIB) support



T1 Features

- Super Frame and Extended Super Frame (SF/ESF)
- BERT
- Local loopback
- Generates and terminates FDL in ESF framing
- RFC 1406 MIB support

E1 Features

- Unframed E1 or basic and cyclic-redundancy-check (CRC)-4 G.706 framing
- BERT
- Local loopback
- RFC 1406 MIB support

T3 Alarms

- Alarm indication signal (AIS)
- Out of Frame (OOF)

T1 Alarms

- AIS
- Loss of signal (LOS)

E1 Alarms

- AIS
- OOF
- Resource availability indicator (RAI)

Physical Features

- Occupies one slot in any Cisco 7600 Series or Cisco Catalyst 6500 Series chassis
- Mini-SMB coaxial connectors
- Dimensions (H x W x D): 1.2 x 14.4 x 16 in. (3.0 x 35.6 x 40.6 cm)
- Power required: 118W
- Status indicators and interfaces:
 - Green (operational)
 - Red (faulty)
 - Orange (module booting or running diagnostics)



Environmental Conditions

- Storage temperature: –38 to 150°F (–40 to 70°C)
- Operating temperature: 41 to 104°F (5 to 40°C)
- Storage relative humidity: 5 to 95% relative humidity
- Operating humidity, nominal: 5 to 85% relative humidity
- Operating humidity, short-term: 5 to 90% relative humidity
- Operating altitude: –60 to 4000 m

Network Management

- Fully configurable using the Cisco IOS Software CLI
- Telnet (using CLI)
- Console port (using CLI)
- Simple Network Management Protocol (SNMP)
- DS3 MIB (RFC 1407)
- DS1 MIB (RFC 1406)
- MIB-II (RFC 1213)

Safety

UL 1950 Third Edition

CSA 22.2 No. 950 Third Edition

EN 60950

IEC 950

TS001

EMC

FCC Part 15 (CFR 47) Class A

ICES-003 Class A

EN55022 Class A

CISPR22 Class A

AS/NZS 3548 Class A

VCCI Class A

EN55024

ETS300 386

EN50082-1

EN61000-3-2

EN61000-3-3

EN61000-6-1

Cisco Systems, Inc.

All contents are Copyright © 1992–2003 Cisco Systems, Inc. All rights reserved. Important Notices and Privacy Statement.

Page 6 of 7

Industry Standards

GR-63-Core NEBS Level 3 (pending)
GR-1089-Core NEBS Level 3 (pending)
ETSI 300 019 Storage Class 1.1
ETSI 300 019 Transportation Class 2.3
ETSI 300 019 Stationary Use Class 3.1

Service and Support

Cisco offers numerous service and support offerings for both service provider and enterprise customers. Cisco has earned the highest customer satisfaction ratings in the industry by providing the world-class service and support necessary to deploy, operate, and optimize networks. Whether the goal is speed to market,

maximizing network availability, or enhancing customer satisfaction and retention, Cisco is committed to the success of its customers.

For More Information

For more information about Cisco service and support programs and benefits, visit:
<http://www.cisco.com/en/US/support/index.html>
For more information about Cisco 7600 Series routers, contact your Cisco account representative or visit:
<http://www.cisco.com/go/7600>
For ordering information, visit:
http://www.cisco.com/public/ordering_info.shtml



Corporate Headquarters
Cisco Systems, Inc.
170 West Tasman Drive
San Jose, CA 95134-1706
USA
www.cisco.com
Tel: 408 526-4000
800 553-NETS (6387)
Fax: 408 526-4100

European Headquarters
Cisco Systems International BV
Haarlerbergpark
Haarlerbergweg 13-19
1101 CH Amsterdam
The Netherlands
www-europe.cisco.com
Tel: 31 0 20 357 1000
Fax: 31 0 20 357 1100

Americas Headquarters
Cisco Systems, Inc.
170 West Tasman Drive
San Jose, CA 95134-1706
USA
www.cisco.com
Tel: 408 526-7660
Fax: 408 527-0883

Asia Pacific Headquarters
Cisco Systems, Inc.
Capital Tower
168 Robinson Road
#22-01 to #29-01
Singapore 068912
www.cisco.com
Tel: +65 6317 7777
Fax: +65 6317 7799

Cisco Systems has more than 200 offices in the following countries and regions. Addresses, phone numbers, and fax numbers are listed on the **Cisco Web site at www.cisco.com/go/offices**

Argentina • Australia • Austria • Belgium • Brazil • Bulgaria • Canada • Chile • China PRC • Colombia • Costa Rica • Croatia
Czech Republic • Denmark • Dubai, UAE • Finland • France • Germany • Greece • Hong Kong SAR • Hungary • India • Indonesia • Ireland
Israel • Italy • Japan • Korea • Luxembourg • Malaysia • Mexico • The Netherlands • New Zealand • Norway • Peru • Philippines • Poland
Portugal • Puerto Rico • Romania • Russia • Saudi Arabia • Scotland • Singapore • Slovakia • Slovenia • South Africa • Spain • Sweden
Switzerland • Taiwan • Thailand • Turkey • Ukraine • United Kingdom • United States • Venezuela • Vietnam • Zimbabwe

All contents are Copyright © 1992-2003 Cisco Systems, Inc. All rights reserved. Catalyst, Cisco, Cisco IOS, Cisco Systems, and the Cisco Systems logo are registered trademarks of Cisco Systems, Inc. and/or its affiliates in the U.S. and certain other countries.

All other trademarks mentioned in this document or Web site are the property of their respective owners. The use of the word partner does not imply a partnership relationship between Cisco and any other company. (0303R) DB/LW4321 0303